

# DROP BOTTOM SKIP WITH HEEL CAGE SAFETY



**Full bottom emptying.  
Best size/capacity ratio.  
With patented heel cage safety - no risk of disengaging.**



**Automatic fork heel locking** with stub cage safety (registered patent)

**Full hold** in heel cage by apron movement



**Version with or without wheels**

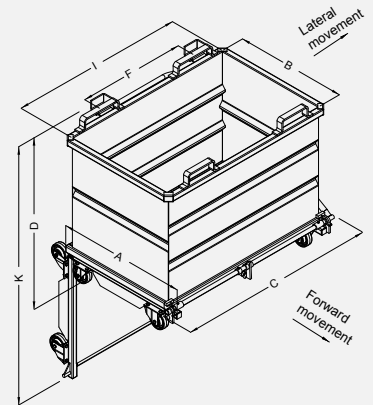
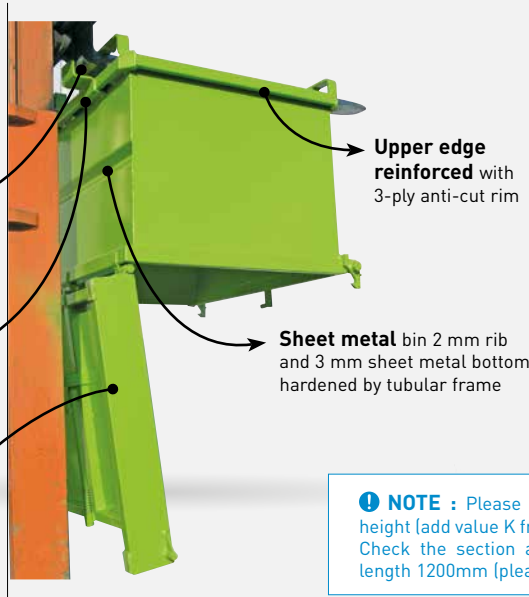

**NOTE :** Please ensure the forklift mast is at a suitable height (add value K from the table to the collection skip height). Check the section and the length of the forks - minimum length 1200mm (please contact us if lower length).



**Heel cage safety :** fully secure hold



**Galvanized version with castors - forward movement**



**Automatically tips on contact**

## CHARACTERISTICS

- Capacity : 515 to 2075 litres
- Upper lifting lugs, aperture : 160 x 60 and spacing (F) 700 mm
- Opening mechanism tied with hinged hook
- Automatically unlocks and tips on contact, lever for manual tipping
- Safety latch preventing any unintentional use
- Models without wheels for use with pallet truck
- Caster mounted models have 2 fixed and 2 pivoting castors and a handrail Forward movement except for 2075 L which has lateral motion
- For customised or reinforced versions, please contact us

| Capacity litres | Load kg | Castors Ø | A    | B    | C    | I    | D    | K    | Weight kg | Painted ref. |
|-----------------|---------|-----------|------|------|------|------|------|------|-----------|--------------|
| 515             | 1500    | -         | 1010 | 800  | 1145 | 1000 | 880  | 1620 | 125       | CAP05000     |
| 515             | 1200    | 125N      | 1005 | 800  | 1145 | 1000 | 930  | 1620 | 130       | CAP05120     |
| 830             | 1500    | -         | 1000 | 800  | 1395 | 1250 | 1070 | 1810 | 155       | CAP08000     |
| 830             | 1200    | 125N      | 1005 | 800  | 1395 | 1250 | 1120 | 1810 | 160       | CAP08120     |
| 1000            | 1500    | -         | 1010 | 800  | 1345 | 1200 | 1280 | 2020 | 165       | CAP10000     |
| 1000            | 1200    | 150P      | 1005 | 800  | 1345 | 1200 | 1380 | 2020 | 175       | CAP10151     |
| 1400            | 1500    | -         | 1100 | 900  | 1395 | 1250 | 1425 | 2265 | 185       | CAP14000     |
| 1400            | 1200    | 150P      | 1105 | 900  | 1395 | 1250 | 1520 | 2265 | 195       | CAP14151     |
| 2075            | 2000    | -         | 1220 | 1000 | 1945 | 1800 | 1390 | 2350 | 255       | CAP20000     |
| 2075            | 1800    | 160P      | 1225 | 1000 | 1980 | 1800 | 1490 | 2350 | 267       | CAP20161     |

Castors : N = Nylon, P = alu/polyurethane - Dimensions in mm for basic model (for guidance only).

# OPTIONS AND FUNCTIONS OF USE

FAP CAP



Lid with inspection window and ferrule



Opening limiter with guide flanges



Lid with 2 opening sections



Lid with 1 hinged section

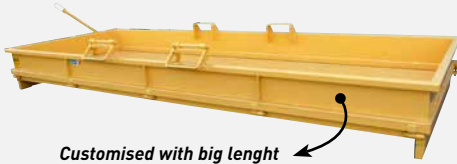

Customised with big lenght



4 corner lifting lugs

Automatic release by contact drawbar

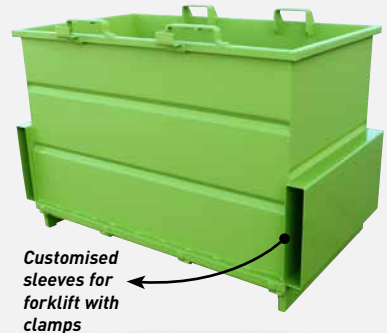

Customised sleeves for forklift with clamps



Custom made product with roof



Opening limiters



Lower lifting through fork sleeves